

Bulletin 4208

Thruster Drum Brakes

Catalog

18

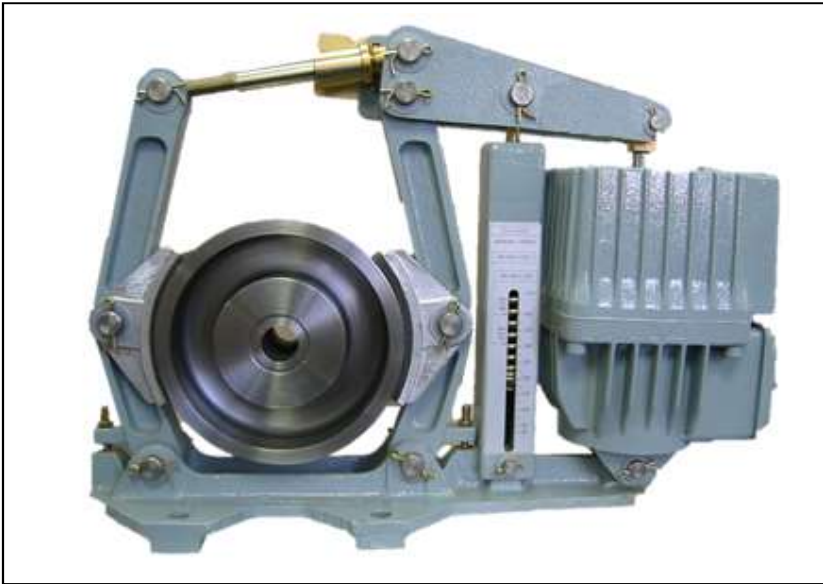

CONTENTS

Descriptions	Page
Thruster Drum Brakes	
General Information	2
Technical Specification	2
Ordering Information	3
Application Data	4
Brake and Wheel Weights	5
Spare Shoe Kits	7
Brake Dimensions	8



Industrial Controls Division

Bulletin 4208

Thruster Drum Brakes

GENERAL INFORMATION

BULLETIN 4208 THRUSTER DRUM BRAKES

The thruster drum brakes are spring set, electrically released, drum type friction brakes used with AC motors.

- Designed to AIST Technical Report 11
- **Standard “self-adjuster mechanism” compensates for lining wear**
- **Standard adjustable “external torque spring” with calibrated torque scale**
- Standard ground stainless steel pins on all brake sizes
- Self-lubricating bushings in all major pivot locations
- Brake frame: Epoxy paint
- Friction material: Organic
- Used as holding or stopping brake on AC applications such as cranes, conveyors, or movable bridges

TECHNICAL SPECIFICATION

- 8” to 30” Industrial duty drum brakes
- Torque range available from 45 – 9000 lb-ft.
- Brake lining friction coefficient $\mu = 0.42$
- Electrohydraulic thruster: IP65 rated enclosure
- Thruster motor: Class F insulation (maximum operating temperature 155°C)
- Operating voltages: 460/230 3Ph, 60 Hz or 380/220 3Ph, 50 Hz, ($\pm 10\%$)
- Thruster hydraulic fluid operating range (-20°C to +55°C)
- AIST TR-11 mounting dimensions

Typical Thruster Response	8”	10”	13”	16”	19”	23”
Brake Release Time	0.2 sec	0.2	0.2	0.2	0.2	0.2
Brake Set Time	0.35 sec	0.35	0.35	0.4	0.4	0.45

Thruster Power Requirements – Maximum Current

Thruster	Hz	Volt Y	Amps Y	Volt Δ	Amps Δ	RPM
All Brake Size's	60	460	1.0	230	2.0	3350
All Sizes Size's	50	380	1.2	220	2.0	2770

ORDERING INFORMATION

Brake Size	AIST Rating (lb-ft)	Maximum Design Non-AIST Rating (lb-ft)	Minimum Torque (lb-ft)	Type	Thruster Voltage Code ▼
8	100	220	45	TS08	3 or 4
10	200	240	50	TS10	3 or 4
13	550	640	130	TS13	3 or 4
16	1000	1190	250	TS16	3 or 4
19	2000	2140	450	TS19	3 or 4
23	4000	4350	900	TS23	3 or 4
30	9000	Consult Factory			

▼ Voltage Code: 3 = 380/220V 3Phase, 50 Hz
 4 = 460/230V 3Phase, 60 Hz
 Example: 4208 TS08 3 = 8" Brake with 380/220V, 50HZ Thruster

Brake Modifications

Form	8"	10"	13"	16"	19"	23"
KR – Limit Switch Release/Set	●	●	●	●	●	●
KW – Limit Switch Wear	●	●	●	●	●	●
KH – Limit Switch Hand Release	●	●	●	●	●	N/A
MR – Manual Release right side ▲	●	●	●	●	●	N/A
ML – Manual Release left side ▲	●	●	●	●	●	N/A
DB – Dust Boot	●	●	●	●	●	●
DV – Time Delay Valve (up to 5 sec)	●	●	●	●	●	●
EX – Extended Temp Oil ◇	●	●	●	●	●	●

◇ Thruster Operating Range (-40°C to 107°C)
 ▲ Manual release is normally mounted on right side of brake. There is an option to mount on left side.
 See brake outline on page 8 which identifies right & left side of brake.

Ordering Information Required:

1. For Thruster Drum Brake
 - a. Bulletin
 - b. Type
 - c. Voltage Code
 - d. Modification: Specify Form letters
 - e. With or without wheel
2. For brake wheel purchased with brake:
 Supply the dimensions required for ordering wheels. (page 4)

Ordering Example: 16" brake, 460V, 3PH, 60HZ, with manual release on left side, limit switch wear indicator and dust boot without a brake wheel.
 Catalog No: **4208 TS164, ML, KW, DB, without wheel**



**Bulletin 4208
Thruster Drum Brakes**

APPLICATION DATA

**Approximate Dimensions—Ductile Iron Brake Wheels
Standard Semi-Finished Wheel Dimensions ▲**

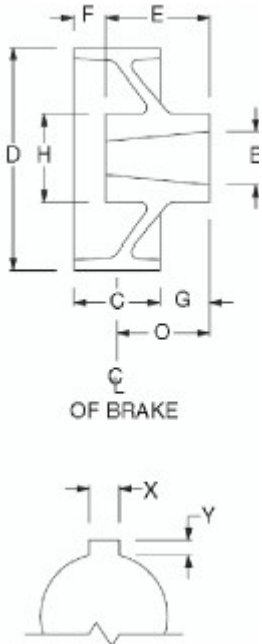

Standard Wheel Dimensions Inches (mm) (Consult Factory for Non-Standard Dimensions)							Machining Limitations Inches (mm)		
D	C	E	F	G	H	O	F	O	M*
							Max.	Min.	
8	3.25 (83)	3.0 (76)	2.6 (66)	2.4 (61)	3.25 (83)	4.05 (103)	2.7 (69)	2.6 (66)	0.38 (10)
	3.25 (83)	6.9 (175)	0.2 (5)	3.9 (99)	3.25 (83)	5.55 (141)	2.7 (69)	2.6 (66)	0.38 (10)
	3.25 (83)	5.6 (142)	0.8 (20)	3.1 (79)	3.7 (94)	4.75 (121)	2.6 (66)	2.4 (61)	0.38 (10)
10	3.75 (95)	3.5 (89)	2.6 (66)	2.4 (61)	4.0 (102)	4.25 (108)	3.1 (79)	2.8 (71)	0.50 (13)
	3.75 (95)	6.3 (160)	1.5 (38)	4.0 (102)	4.0 (102)	5.85 (149)	3.1 (79)	2.8 (71)	0.50 (13)
	3.75 (95)	6.0 (152)	1.5 (38)	3.8 (97)	4.7 (119)	5.65 (144)	2.8 (71)	2.5 (64)	0.50 (13)
13	5.75 (146)	4.5 (114)	3.7 (94)	2.5 (64)	5.5 (140)	5.35 (136)	4.5 (114)	3.4 (86)	0.63 (16)
	5.75 (146)	8.6 (218)	0.9 (23)	3.8 (97)	5.5 (140)	6.65 (169)	4.5 (114)	3.4 (86)	0.63 (16)
	5.75 (146)	5.5 (140)	3.0 (76)	2.8 (71)	6.5 (165)	5.65 (144)	4.1 (104)	3.0 (76)	0.63 (16)
16	6.75 (171)	4.5 (114)	5.4 (137)	3.1 (79)	5.5 (140)	6.45 (164)	6.0 (152)	5.4 (137)	0.63 (16)
	6.75 (171)	8.5 (216)	2.9 (74)	4.6 (117)	5.5 (140)	7.95 (202)	6.0 (152)	5.4 (137)	0.63 (16)
	6.75 (171)	5.8 (147)	4.1 (104)	3.1 (79)	6.5 (165)	6.45 (164)	5.4 (137)	4.9 (124)	0.63 (16)
19	8.75 (222)	5.0 (127)	6.9 (175)	3.1 (79)	6.6 (168)	7.45 (189)	7.0 (178)	6.0 (152)	0.75 (19)
	8.75 (222)	7.8 (198)	5.0 (127)	4.0 (102)	6.6 (168)	8.35 (212)	7.0 (178)	6.0 (152)	0.75 (19)
	8.75 (222)	9.3 (236)	3.5 (89)	4.0 (102)	9.0 (229)	8.35 (212)	6.1 (155)	4.9 (124)	0.75 (19)
23	11.25 (286)	6.0 (152)	8.4 (213)	3.1 (79)	8.0 (203)	8.7 (221)	8.8 (224)	6.9 (175)	1.0 (25)
	11.25 (286)	9.2 (234)	5.3 (135)	3.2 (81)	8.0 (203)	8.8 (224)	8.8 (224)	6.9 (175)	1.0 (25)
	11.25 (286)	10.2 (259)	5.4 (137)	4.2 (107)	10.0 (254)	15.6 (396)	8.1 (206)	6.2 (157)	1.0 (25)
30	14.25 (362)	7.3 (185)	10.6 (269)	3.6 (91)	12.5 (318)	10.7 (272)	10.5 (267)	9.4 (239)	1.38 (35)
	14.25 (362)	10.1 (257)	7.8 (198)	3.6 (91)	12.5 (318)	10.7 (272)	10.5 (267)	9.4 (239)	1.38 (35)

▲ An extra charge may be made for special wheels which cannot be machined from the standard semi-finished wheels detailed above. Consult factory for pricing.

* Minimum material required over keyway.

Dimensions Required for Ordering Wheels:

BASIC WHEEL DIMENSIONS:

D = _____
E = _____
F = _____

BORE DIMENSIONS:

B = _____
T = Bore Taper (Indicate One):
_____ Straight
_____ Tapered 1.25"/Ft.
_____ Tapered 1.219"/Ft.

KEYWAY DIMENSIONS:

X = Width = _____
Y = Depth = _____
Ymax = 1/2 X

Notes:

- For semi-finished wheel (solid hub: no bore or keyway):
 - State "Semi-finished wheel is required" on order.
 - Supply D, E & F dim. ONLY
- For any set of wheel dimensions $E + F = 1/2C + O$
- Formula for maximum bore: $B_{max} = H - 2(M + Y)$
- Pilot bore = 1"

Replacement Ductile Iron Brake Wheels

AIST Standard

Brake Wheels designed for use with Bulletin 4208 Thruster Drum Brakes
8" to 30" Wheels (diameter in inches)



APPLICATION DATA

Ratings, Weight and Wheel Data

Brake Size (Wheel dia. In inches)	Maximum Torque Rating (lb-ft ²)	WR ² of Wheel (lb-ft ²)	Approximate Net Weight lbs (kg)		Maximum Allowable Speed (RPM)
			Brake Only	Wheel Only	
8	100	1	75 (34)	17 (7.7)	5000
10	200	2.7	95 (43)	25 (11.3)	4000
13	550	10	175 (79)	60 (27)	3300
16	1000	30	245 (111)	110 (50)	2800
19	2000	72	325 (147)	175 (79)	2300
23	4000	178	564 (256)	300 (136)	1900
30	9000	600	924 (419)	765 (347)	1600

BRAKE TORQUE SELECTION

Brakes are selected by the amount of brake torque required for the particular application. Generally, the full load torque of the motor is used as a basis for determining the brake torque required. This can be calculated by using the following formula for both AC or DC motors:

$$\text{Torque} = \frac{\text{Rated HP} \times 5252}{\text{Rated RPM}}$$

Depending on the characteristics of the drive, the brake torque required may be more or less than the full load torque of the motor.

Once the required brake torque is determined, choose a brake size from the rating table below that has a maximum torque rating of not less than the brake torque required. In addition, if the running speed of the motor is over 600 rpm and the brake service is severe, do not exceed 90% of the maximum rated torque.

HOIST BRAKE SELECTION

AIST Technical Report No. 6, CMAA Specification No. 70, and OSHA Regulations state that the hoist brake is to be selected based on the torque required to hoist rated crane load at the point where the brake is applied.

All three standards require that a hoist drive handling hot metal be equipped with more than one brake.

Basis for Selection of Brake Torque		Brake Torque Rating			
		Hoist Drive with Single Brake		Hoist Drive with Two or More Brakes ♦	
		With Control Braking ■	With Mechanical Load Brake	Handling Hot Metal	Not Handling Hot Metal
CMAA	Torque Required to Hoist Rated Load	125%	100%	100%	100%
OSHA	Torque Required to Hoist Rated Load	125%	100%	100%	100%
AIST	Torque Required to Hoist Rated Load	150%	150%	125%	100%

■ Control braking is dynamic braking, dynamic lowering, countertorque or eddy current load brake.

♦ Failure of any one brake will not cause the remaining torque to fall below levels shown.



Bulletin 4208

Thruster Drum Brakes

Bridge and Trolley Brake Selection

The three standards provide guidelines for the application of brakes to bridge and trolley drives.

Application	Interpretation	Recommendation
Cab-Operated Cranes with The cab located On the Bridge	Bridge A bridge brake of the stopping or holding type is required. Trolley A trolley brake of the stopping or holding type is required.	OSHA defines a brake as "a device used for retarding or stopping motion by friction or power means". "A drag brake is a brake which provides retarding force without external control".
Cab-Operated Cranes with the cab located on the Trolley	Bridge A bridge brake of the holding type is required. Trolley A trolley brake of the stopping or holding type is required.	"A holding brake is a brake that automatically prevents motion when power is off". AISE and OSHA specify that stopping brakes be selected to (1) stop the drive within a distance in feet equal to ten percent of full load speed in feet per minute when traveling at full speed with full load. (2) stop the drive from full load free running speed to zero speed at a deceleration rate equal to the acceleration rate for the drive.
Floor, Remote and Pulpit-Operated Cranes	Bridge A bridge brake of the stopping or holding type or non-coasting mechanical bridge drive is required. Trolley A trolley brake is not required but one may be used to eliminate creep with the power off.	

Application	Brake Torque Ratings •			
	Bridge		Trolley	
	AIST	CMAA	AIST	CMAA
Cab-operated cranes with the cab located on the bridge	See Below	100%	50%	50%
Cab-operated cranes with the cab located on the trolley	100%	75%	--	100%
Floor, Remote, and Pulpit-operated cranes	100%	50%	50%	50%

- Ratings are based on motor full load torque.

OSHA does not specify brake torque rating in percent of motor full load torque for bridge and trolley drives. Usually the limiting factor for selection of the brake size is the thermal capability of the brake wheel for the frequency of operation required by the service. Similarly, for cab-operated cranes with the cab located on the bridge, AIST requires a brake of the stopping type for the bridge. The brake must be capable of stopping the bridge from full speed in a distance in feet not greater than 10% of the full load speed in fpm. Also the thermal capacity must be adequate for the duty. For cab-operated cranes with the cab located on the trolley, AIST requires a brake of the stopping type for the trolley. It must be sized similar to the bridge brake.

Brake Selection-Thermal Capability

In addition to being selected to meet the torque requirements of the particular application, the brake used for stopping must be selected to prevent overheating of the brake wheel when operated on the anticipated duty cycle.

To calculate how often a stop can be made from full speed without overheating the brake wheel:

$$\frac{(kl) \times (CWL) \times (SL)^2}{(B) \times (M)} = \text{_____ Seconds}$$

(M) = Number of motors

CWU = Crane weight (tons)

CWL = Crane weight loaded (tons) = (CWU + CL)

(SL) = Free-running speed loaded (FPM)

(B) = Number of brakes per motor

CL = Crane Load (tons)

(SU) = Free-running speed unloaded (FPM)

(kl) = Constant (see table)

A stop can be made from full speed this often without overheating the brake wheel. Four times as many stops can be made from half speed in this time interval. For unloaded crane conditions (CWL) and (SL) are replaced by (CWU) and (SU).

Brake Size (Wheel dia. in inches)	(kl)
8	26.50×10^{-6}
10	15.90×10^{-6}
13	9.34×10^{-6}
16	6.10×10^{-6}
19	4.30×10^{-6}
23	3.00×10^{-6}
30	1.76×10^{-6}

Spare Brake Shoe Kits

Aluminum brake shoe assembly with bonded organic lining. (Kit includes 2 shoes)

Brake Size	Type
8	SA08
10	SA10
13	SA13
16	SA16
19	SA19
23	SA23

Ordering Example: 16" Brake Shoe Kit

Catalog No: **4208 SA16**

Bulletin 4208

Thruster Drum Brakes

Approximate Dimensions

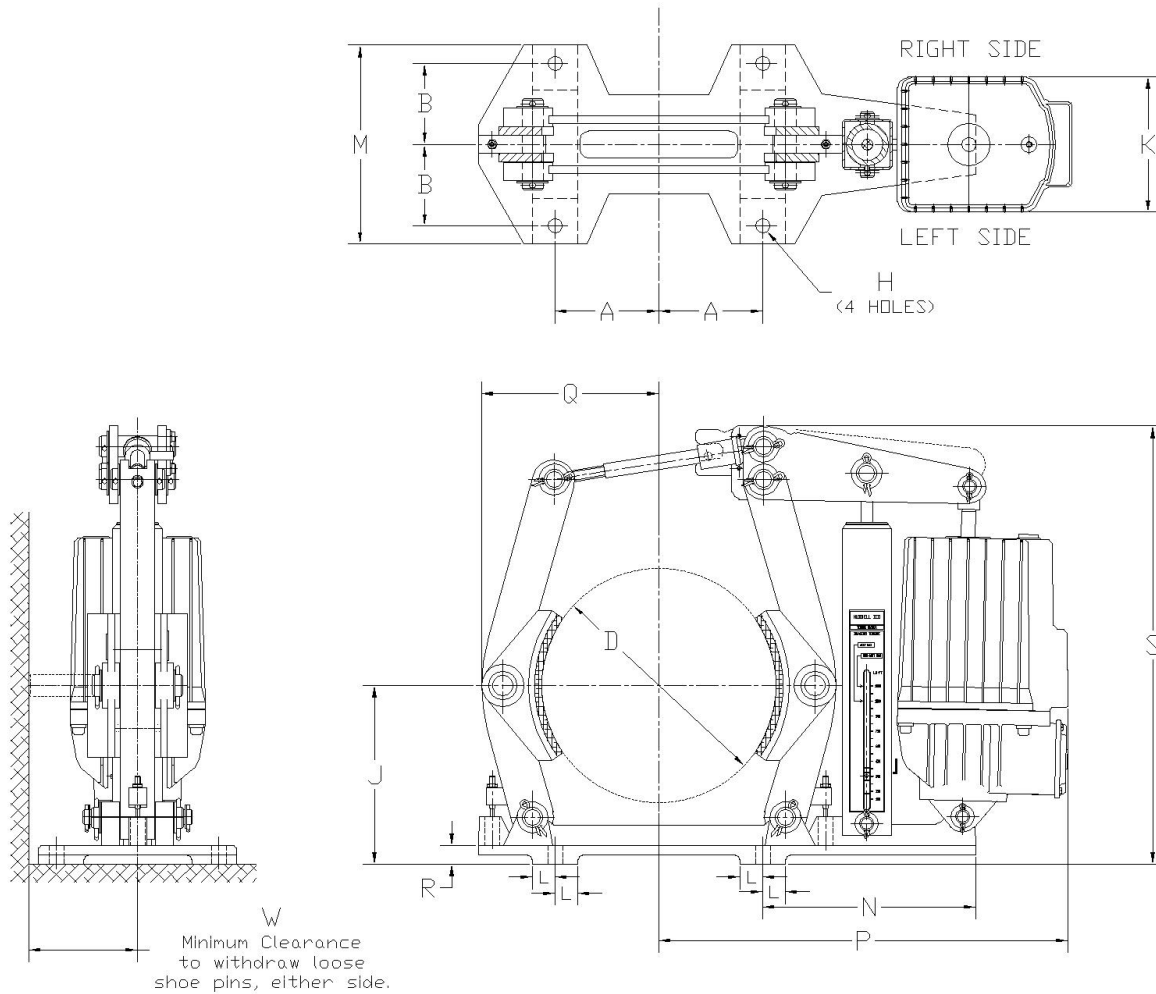

Brake Size	A	B	D	H	J	K	L	M	N	P	Q	R	S	W
8	<u>3.25</u> 83	<u>2.87</u> 73	<u>8.00</u> 203	<u>.69</u> 17	<u>7.00</u> 178	<u>6.30</u> 160	<u>.79</u> 20	<u>7.36</u> 187	<u>9.48</u> 241	<u>16.78</u> 426	<u>6.34</u> 161	<u>1.00</u> 25	<u>16.55</u> 420	<u>4.17</u> 106
10	<u>4.00</u> 102	<u>3.12</u> 79	<u>10.00</u> 254	<u>.69</u> 17	<u>8.39</u> 213	<u>6.30</u> 160	<u>.79</u> 20	<u>7.87</u> 200	<u>10.86</u> 276	<u>16.78</u> 426	<u>7.68</u> 195	<u>1.00</u> 25	<u>19.85</u> 504	<u>5.00</u> 127
13	<u>5.75</u> 146	<u>4.50</u> 114	<u>13.00</u> 330	<u>.82</u> 21	<u>9.88</u> 251	<u>7.48</u> 190	<u>1.25</u> 32	<u>11.00</u> 279	<u>12.15</u> 309	<u>22.66</u> 576	<u>9.82</u> 249	<u>1.00</u> 25	<u>24.25</u> 616	<u>6.02</u> 153
16	<u>7.50</u> 191	<u>5.37</u> 137	<u>16.00</u> 406	<u>1.06</u> 27	<u>12.13</u> 308	<u>7.48</u> 190	<u>1.28</u> 33	<u>13.00</u> 330	<u>13.25</u> 337	<u>25.24</u> 641	<u>11.61</u> 295	<u>1.25</u> 32	<u>29.87</u> 759	<u>7.40</u> 188
19	<u>9.25</u> 235	<u>6.50</u> 165	<u>19.00</u> 483	<u>1.06</u> 27	<u>13.25</u> 337	<u>9.45</u> 240	Solid Base	<u>15.75</u> 400	<u>14.20</u> 361	<u>31.06</u> 789	<u>13.84</u> 352	<u>.71</u> 18	<u>31.81</u> 808	<u>9.29</u> 236
23	<u>11.75</u> 298	<u>8.00</u> 203	<u>23.00</u> 584	<u>1.31</u> 33	<u>15.88</u> 403	<u>9.45</u> 240	Solid Base	<u>18.90</u> 480	<u>14.20</u> 361	<u>31.06</u> 789	<u>16.30</u> 414	<u>1.00</u> 25	<u>37.68</u> 957	<u>11.30</u> 287

Dual Dimensions: In
mm